



MI-30605

Smart Bias Tee

Extended bandwidth



MASS™

Microdata Advanced Site Solutions

With our expertise in site system design we are able to provide a solution for any site sharing or upgrade scenario.

Our focus area is RF-filter based solutions including combiners, multi band TMAs, di-, tri- and quadruplexers.

Our product portfolio supports all frequencies for mobile communication bands ranging from 450 MHz to 6 GHz.

Site and network sharing makes it cost efficient to reach sparsely populated areas where new subscribers can contribute to revenue.

MASS™

Advantage

Increases coverage

more traffic & higher ARPU

Increases capacity

more traffic & higher ARPU

Reduces the cost

of network expansion

Minimizes

site acquisition issues

Specifications

Electrical	
Frequency range	698 — 2690 MHz
IL	0.1 dB
RL	20 dB
Max RF Power	750 W
DC current	2.7 A
Voltage drop	1 V
Intermodulation	-117 dBm @2x43 dBm
Isolation RF - DC	65 dB
Modem frequency	2.176 MHz
Environmental	
Temperature	-40 °C to +65 °C -40 °F to +149°F
Ingress Protection	IP 67
Lightning Protection	10 kA 8/20 µs 3 kA 10/350 µs
Mechanical	
Weight	0.75 kg 1.65 lb
Size (WxHxD)	81x59x47 mm 3.19x2.32x1.85 in
Connectors	
BTS-Side - 7/16 Female (DC GND)	
ANT-Side - 7/16 Female (DC&AISG signalling)	
AISG 8-pin circular Male (IEC 60130-9)	
Pin	Function
3	RS485-B
5	RS485-A
6	9-30 VDC
7	DC return (ground)
1, 2, 4, 8	Not connected

Block Diagram

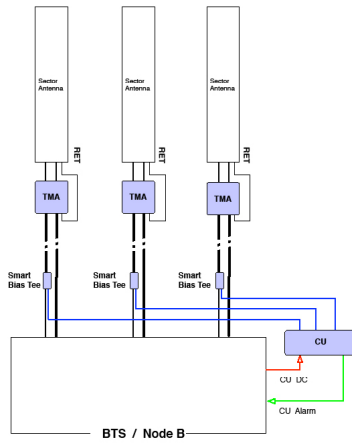

Mechanical Drawing

